

# BALLO L804-500

LED opgradering / LED lighting upgrade / LED upgrade /  
LED uppgradering

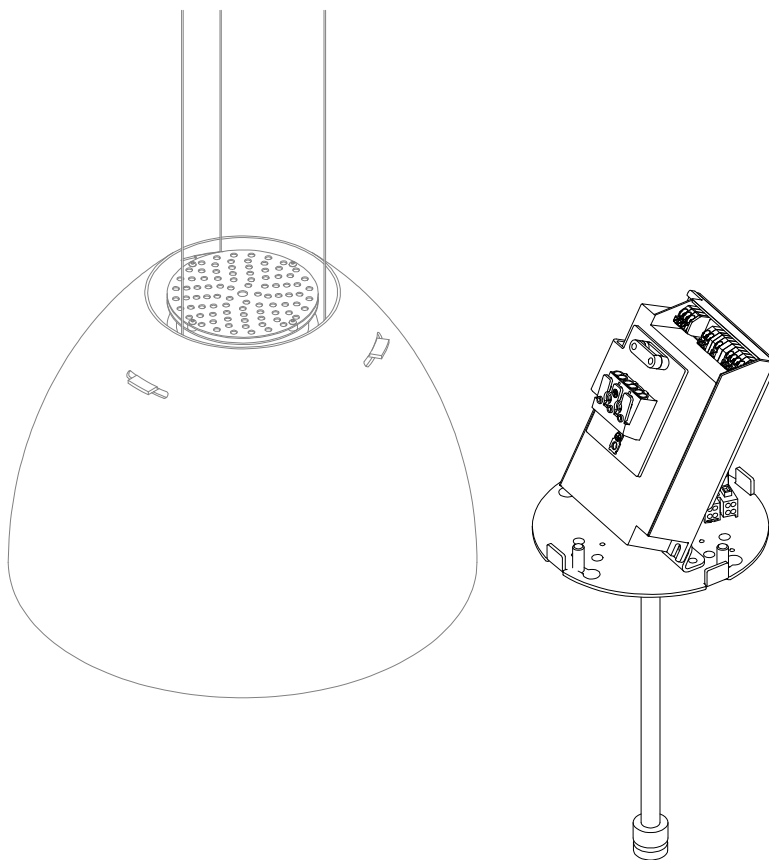

Monteringsvejledning / Mounting instructions /  
Installationsanleitung / Installationsinstruktioner

## Lampas

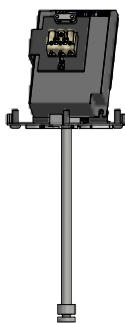
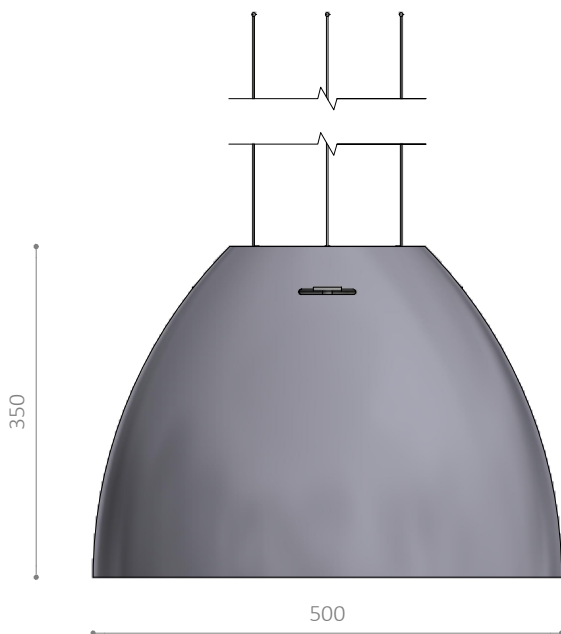

Værktøj / Tool / Werkzeug / Verktøj:



4 mm



PH2

1



PH2

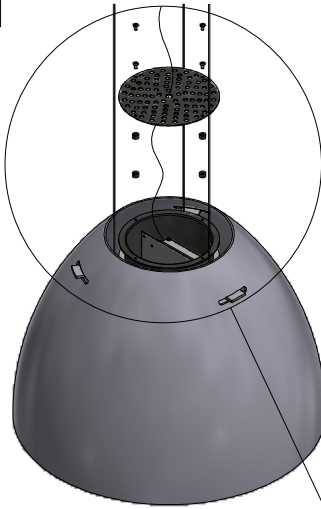

Afbryd strømmen / Turn off the power / Schalten Sie die Stromversorgung aus / Stäng av strømmen

2

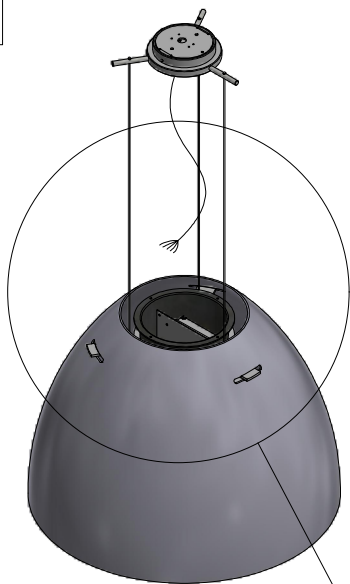

3



4 mm

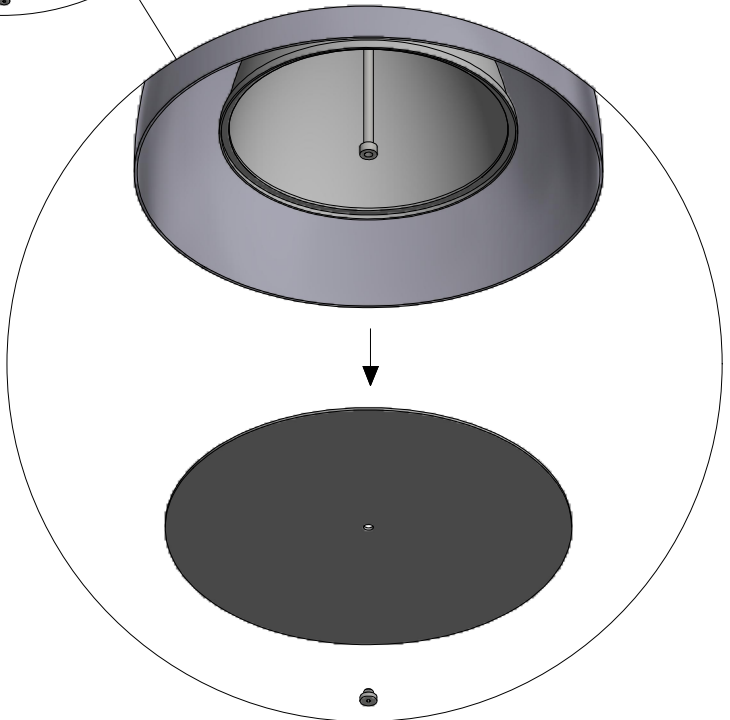
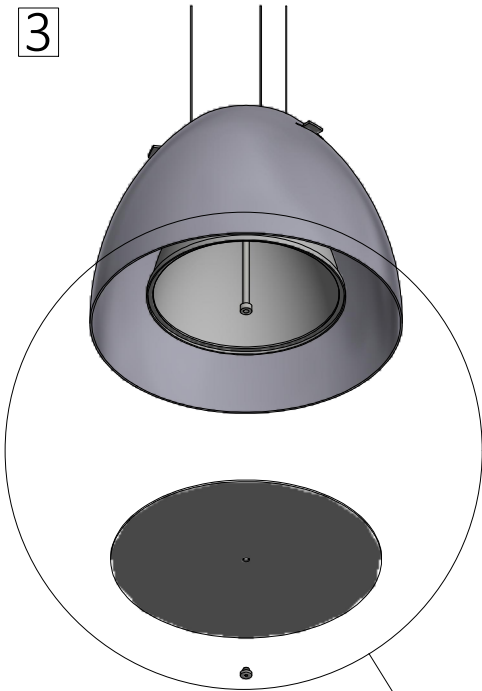

4



PH2

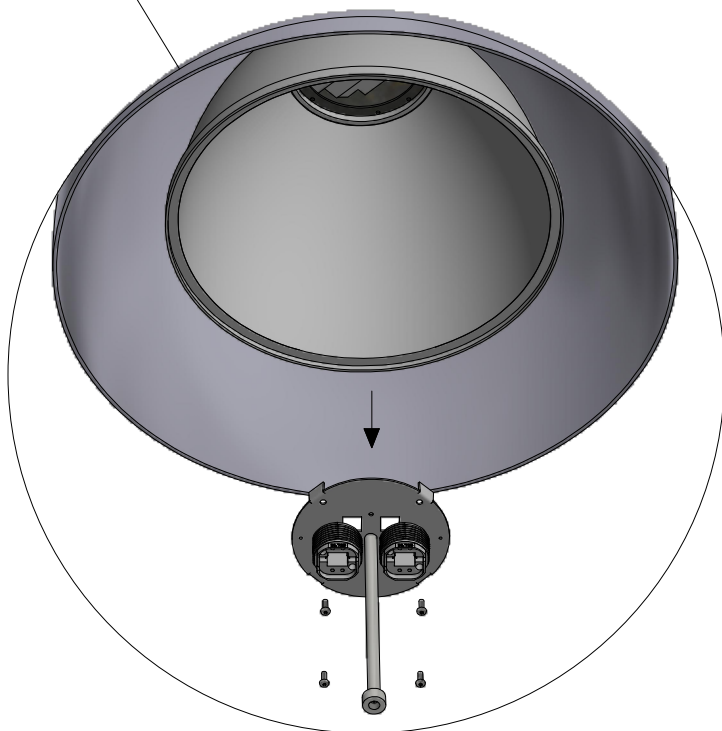
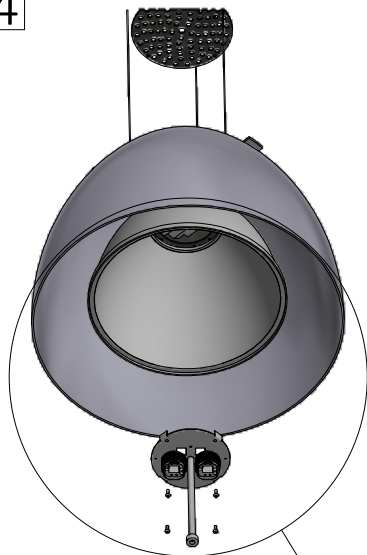

5

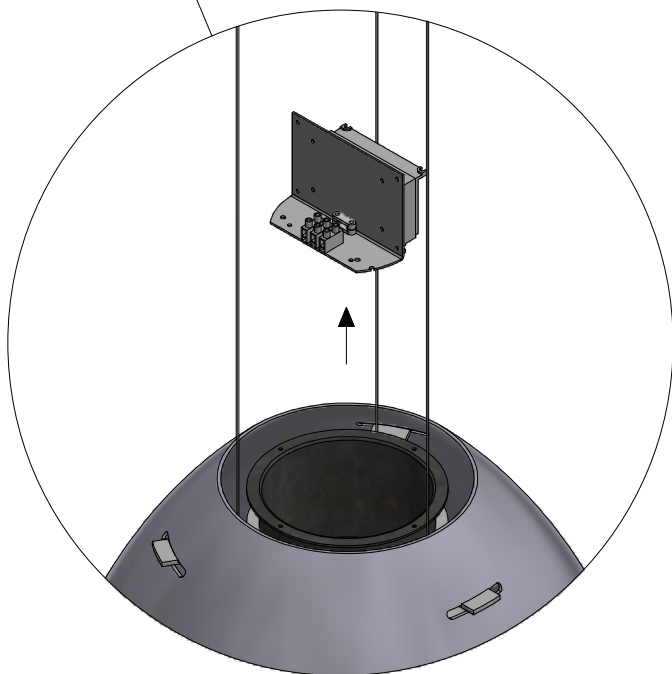
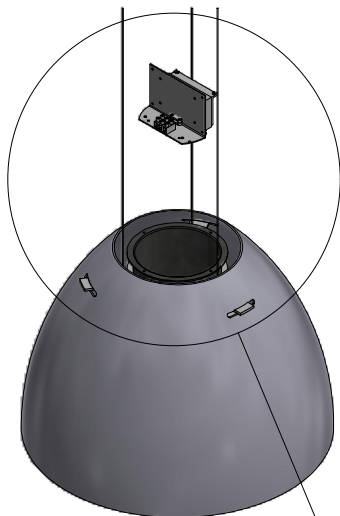

6

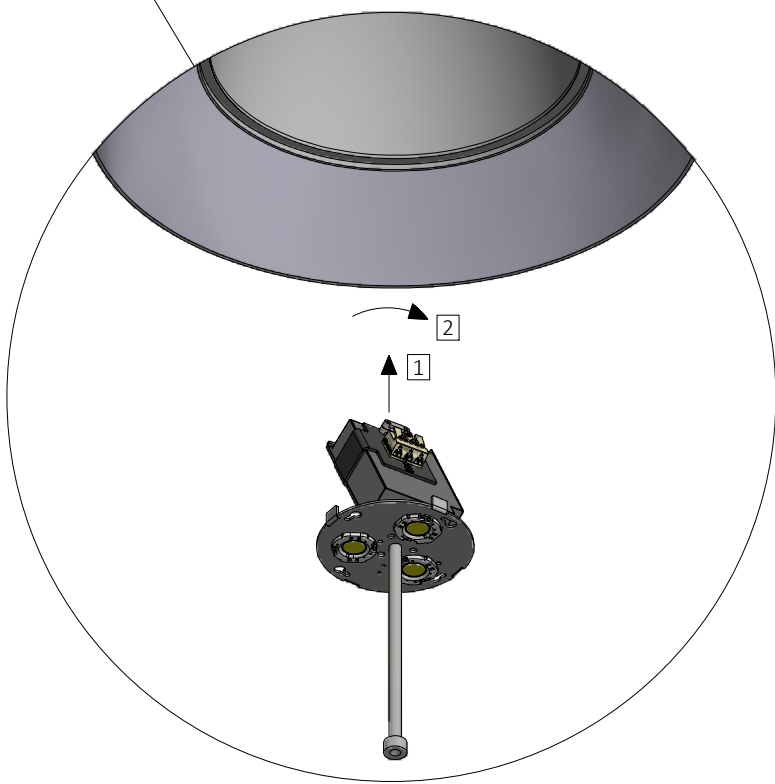
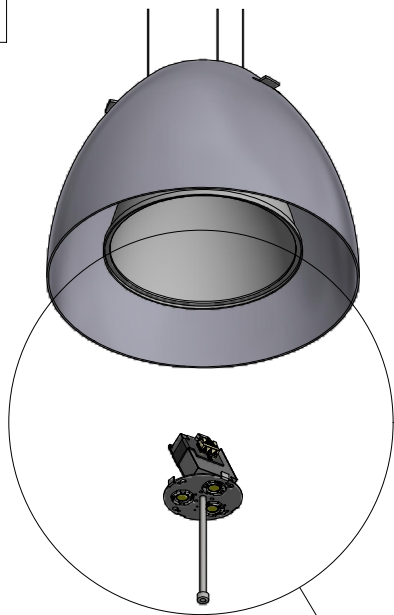



7



4 mm

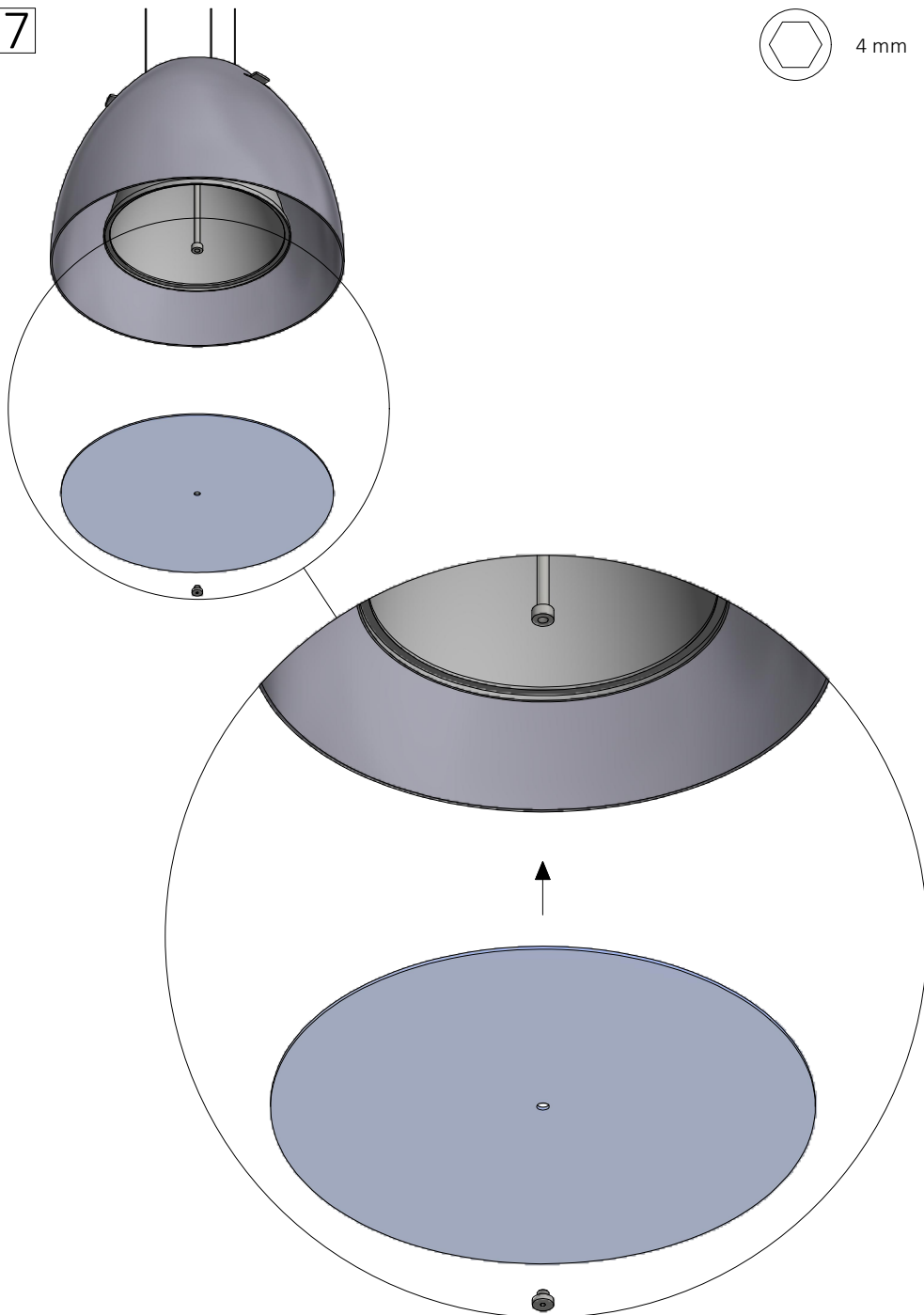

8

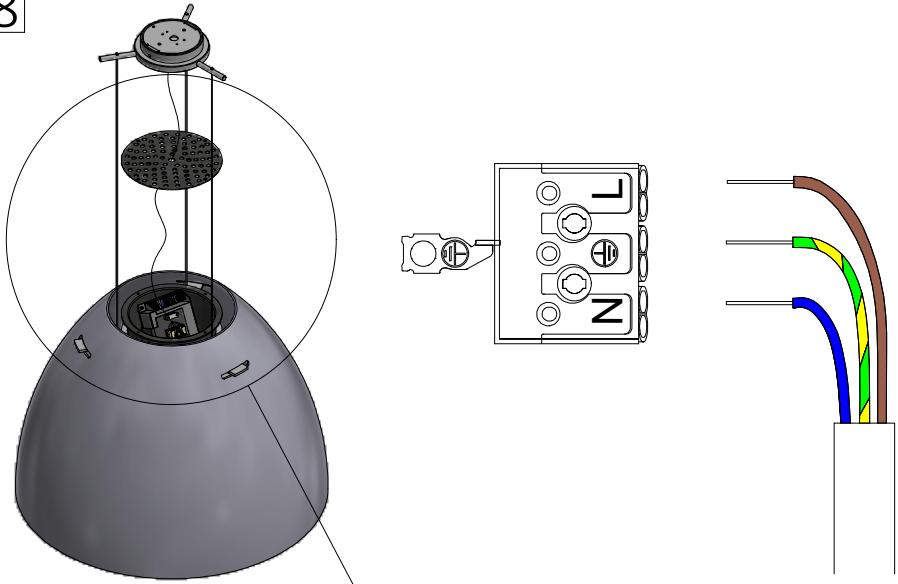

9



PH2

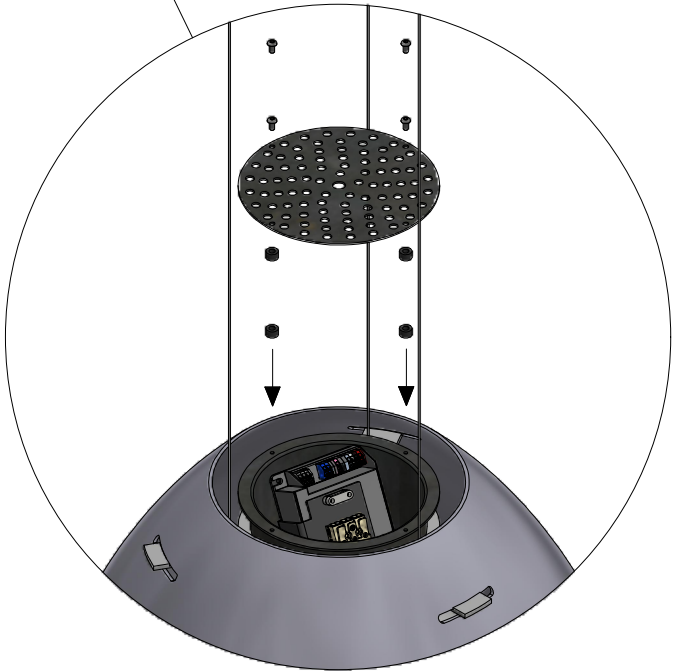
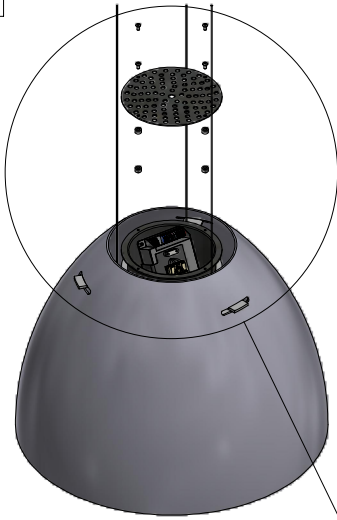



LED



Isolationsklasse I / Insulation class I / Schutzklasse I / Isolationsklass I



0,6 kg



Se vedligeholdelses vejledning / See maintenance instructions /  
Siehe Wartungsanweisungen / Se underhållsinstruktioner



Montering/udskiftning må kun udføres af producenten eller aut. el-installatør /  
Installation/replacement must only be carried out by the manufacturer or by an  
electrician / Die Installation/der Austausch darf nur vom Hersteller oder von  
einem Elektriker durchgeführt werden / Installation / utbyte får endast utföras  
av tillverkaren eller av en behörig elektriker

# Lampas